

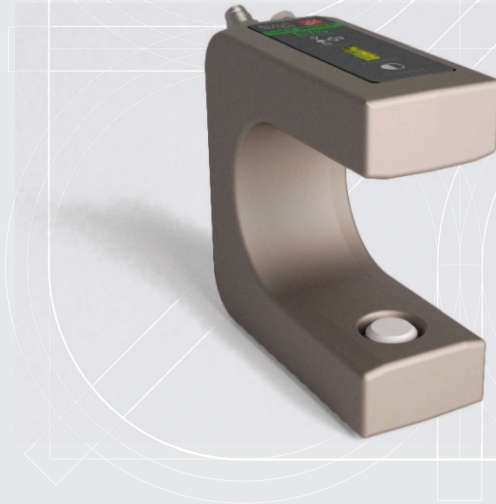

# SU.11

## ULTRASONIC SENSOR



- ✓ Detects the edge of non soundproofing materials
- ✓ Measuring range of 6 mm
- ✓ 0,02 mm of resolution
- ✓ Onboard keyboard
- ✓ Compact design
- ✓ High protection to the noise

The ultrasonic SU sensors are specifically designed for detecting of the edges of materials such as paper, carton, plastic film of any colour or transparent.

The compact design guarantees an easy installation in all kind of applications. SU.11 sensor is equipped with a transmitter and a receiver that guarantees a measuring range of 6 mm with a resolution of 0,02 mm.

SU.11 ultrasonic sensor in the standard version can be used with Re web guiding systems; moreover, the SU.11 MLO version can be used both with Re web guiding systems and also together with a PLC using the tension and current outputs of which it is equipped.

SU.11 is provided with an onboard keypad with two buttons for the calibration and a 5 digit barread, with a double visualization possibility, for an easy and clear control of the web inside the fork

Using two sensors at the same time is it possible to realize the "centre guide": by considering the reading of both edges, the sensors guide the web by keeping the centre as the reference point.

## TECHNICAL DRAWING

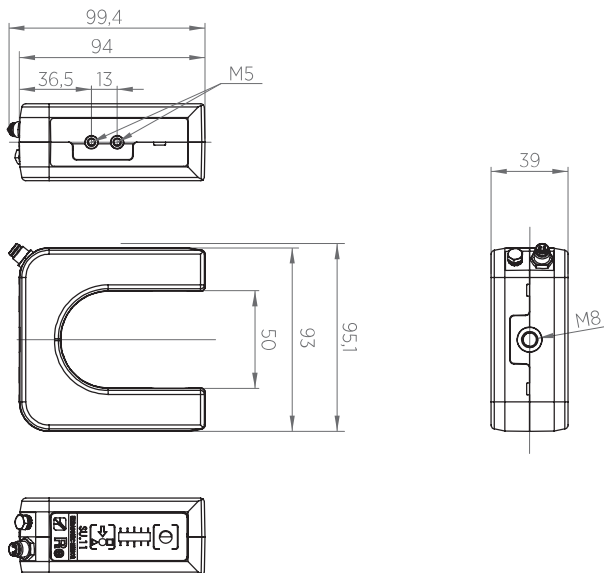

## FUNCTIONING

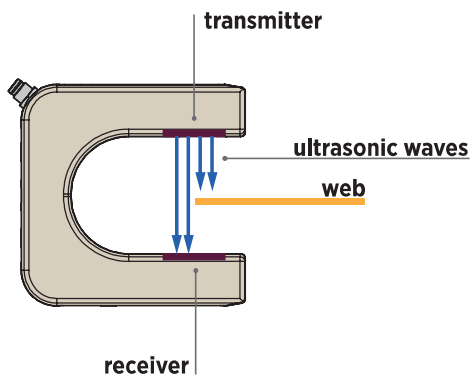

SU.11 is equipped with two ultrasonic capsules, the transmitter one generates an ultrasonic wave sequence which is converted into electric signal by the receiver one. According to the intensity of the signal received, the microprocessor can identify how much of the sensitive surface of the capsule is covered by the material inserted in the fork and calculate the position of the web edge.

## TECHNICAL CHARACTERISTICS

	<b>SU.11</b>	<b>SU.11 MLO</b>
Power supply	12÷24 Vdc	12÷24 Vdc
Power consumption	< 40 mA	< 40 mA
Measuring range	± 3 mm	± 3 mm
Fork width	50 mm	50 mm
Accuracy	0,02 mm	0,02 mm
Ultrasonic frequency	200 kHz	200 kHz
Response time	3 msec	3 msec
Analog outputs	0÷5 Vdc	0÷5 Vdc 0÷10 Vdc -10÷+10V 0÷20 mA 4÷20 mA
Max cable length	5 or 10 m std (max 30 m)	5 or 10 m std (max 30 m)
Working temperature	10÷50° C	10÷50° C
Protection class	IP40	IP40
Dimensions	99,4 x 39 x 95,1 mm	99,4 x 39 x 95,1 mm

\*Data are subject to technical change without notice



Re S.p.A.  
via Firenze 3  
20060 Bussero (MI) Italy

T +39 02 9524301  
F +39 02 95038986  
E [info@re-spa.com](mailto:info@re-spa.com)

Assistenza tecnica  
Technical support  
T +39 02 952430.300  
E [support@re-spa.com](mailto:support@re-spa.com)

Assistenza commerciale  
Sales support  
T +39 02 952430.200  
E [sales@re-spa.com](mailto:sales@re-spa.com)