



CF.85

FLANGE LOAD CELLS



- ✓ Compact design
- ✓ Easy installation
- ✓ High reliability
- ✓ Strain gauge technology
- ✓ Measuring range from 50N to 2000N

A reliable web tension control may reduce web tears in order to increase productivity. CF flange load cells, used in a precise tension control system, are designed to carry out these delicate tasks.

They are installed at the end of a measuring roller to precisely detect the resultant of the forces generated by pulling of the material depending on the wrapping angle.

CF load cells have been designed with a compact design, to easily fit them in narrow spaces, to be installed very easily and to reach a very high reliability.

Operating principle: CF load cells use the strain gauge operating principle to guarantee a perfect detection of the web tension. Strain gauges resistors are mounted on a inner metal foil of a load cell and connected to each other in a "wheatstone bridge" able to convert a mechanical movement into an electrical signal, that must be amplified by suitable amplifiers.

TECHNICAL DRAWING

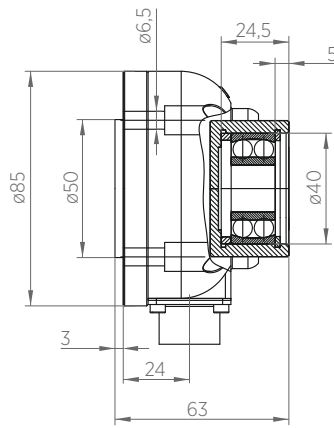
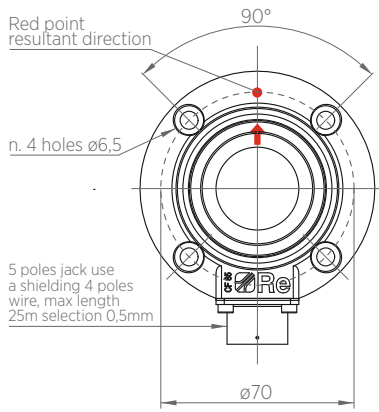

Selection model table

Code	Load N	bearing size
CF.85.5.40	50	40x17
CF.85.15.40	150	40x17
CF.85.25.40	250	40x17
CF.85.50.40	500	40x17
CF.85.100.40	1000	40x17
CF.85.200.40	2000	40x17

* for other model contact our technical dpt.

CF.85.xx.xx

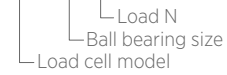

CALCULATION

HORIZONTAL RESULTANT

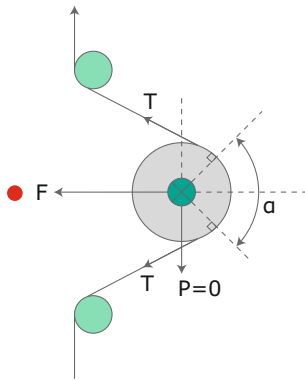

$$F = T \sin \alpha/2$$

DOWNWARD RESULTANT

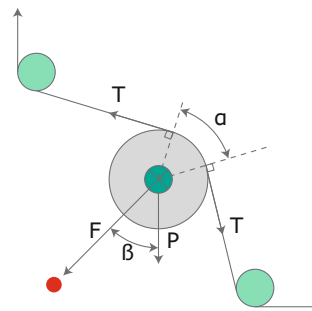

$$F = T \sin \alpha/2 + P/2 \cos \beta$$

UPWARD RESULTANT

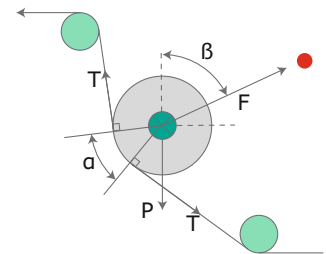

$$F = T \sin \alpha/2 - P/2 \cos \beta$$

TECHNICAL DATA

Precision class		0.5
Sensitivity	Normal Supply	from 1,5mV/V to 2,0mV/V 10V - max 15V
Total error-repeatability-hysteresis-linearity		< ± 0,05% end scale value
Measuring principle		strain gauge full bridge
Strain gauge bridge resistance		350Ω Ohm
Max overload		300%
Temperature range		0°C/+60°C
Option		4-20 mA output

*Data are subject to technical change without notice



Re S.p.A.
via Firenze 3
20060 Bussero (MI) Italy

T +39 02 9524301
F +39 02 95038986
E info@re-spa.com

Assistenza tecnica
Technical support
T +39 02 952430.300
E support@re-spa.com

Assistenza commerciale
Sales support
T +39 02 952430.200
E sales@re-spa.com